



Robotic equipment

Product Overview

INTERNATIONAL EXPERTISE – QUALITY, PRODUCTION & DEVELOPMENT



MURRPLASTIK SYSTEMTECHNIK GMBH

Since its foundation in 1963, Murrplastik Systemtechnik GmbH has been one of the pioneers for high-tech plastic products.

Our design engineers develop innovative universal solutions and customer specific adaptations for the automotive and railway industry, as well as for the tool and mechanical engineering sectors, or for building services.

With more than 200 patents, Murrplastik is one of the world's leading system providers for everything involving: cables and control cabinets.

MURRPLASTIK Portfolio

- Energy chains
- Cable routing
- Labelling
- Cable protection
- Energy supply

OUR EXPERIENCE – YOUR ADVANTAGE

- Precise planning and support for your setup
- Comprehensive system consultations - on-site
- Special wear protection for your robotic equipment
- Innovative solutions for linear axis 7 applications
- Compatibility with other manufacturers
- Spare parts in small packaging quantities
- Short delivery times
- Adapter and fixing plates



CUSTOMISED EQUIPMENT SYSTEMS. THE -SERVICE FOR AUTOMATION & ROBOTIC

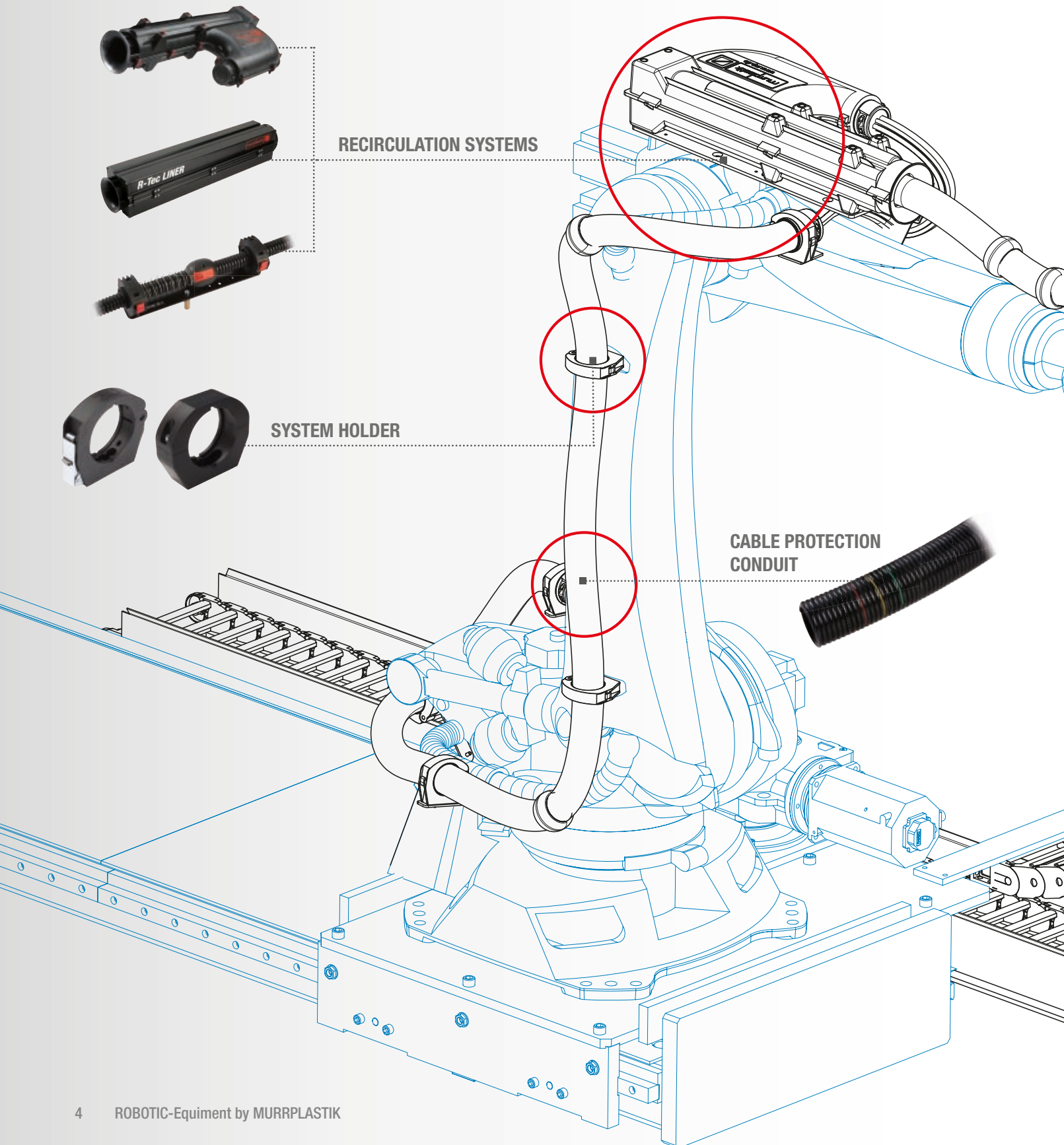



INDIVIDUAL PLANING AND DESIGN

THE SYSTEM MAKES ALL THE DIFFERENCE

Sound MURRPLASTIK advice. Premium individual components, comprehensive performance packages and dresspacks.

Our real strength lies in the system solution. Tailored to your requirements.

Our many years of experience in the business will increase the performance of your robots. Guaranteed!

Contact us for your personalised offer.

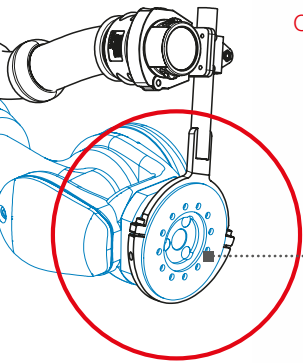

AXIS 6 CONNECTION



CONDUIT STORAGE



PROTECTORS



BALL JOINTS / STRAIN RELIEF

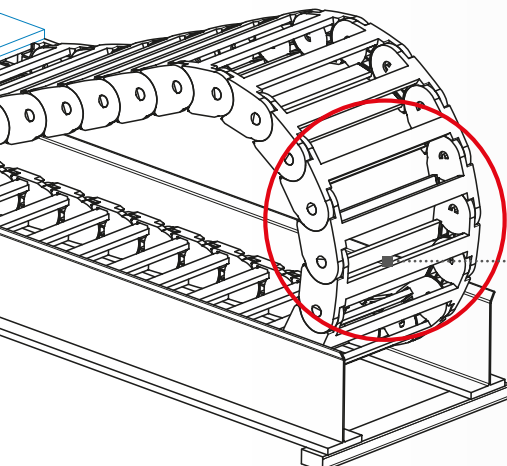

ENERGY CHAIN



LONG SERVICE LIFE DUE TO A RECIRCULATION SYSTEM



DIVERSITY IN RECIRCULATION SYSTEMS

Preventing unnecessary movement, is the basic requirement for a long service life for energy packages of industrial robots. Especially for the installations at axis 3 to axis 6, the lines must be routed to allow utmost flexibility, to facilitate all necessary movements.

This is where our recirculation systems come into play. As a rule, they are mounted on axis 3; they are designed to keep the energy package cables taut at all times, yet allowing freedom of movement.

The guarantee for a long service life!

R-TEC BOX



Size	M32/P29
	M40/P36
	M50/P48
	56/70 Jumbo
Stroke	270 mm
	400 mm
	600 mm

 Optimum guide for the energy packets from axis 3 to axis 6 at industry robots. Secure, low-wear and effective cable routing in the smallest spaces.

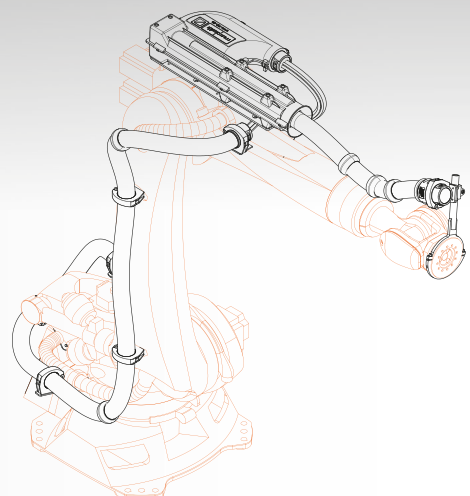

R-TEC LINER



Size	56/70 Jumbo
Stroke	550 mm
	350 mm

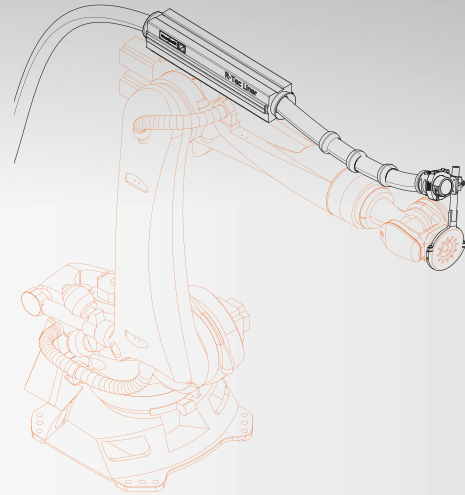

! The linear retraction system by Murrplastik protects your energy package from damage and wear

RECIRCULATION SYSTEM



Size	M25/P21
	M32/P29
Stroke	160 mm

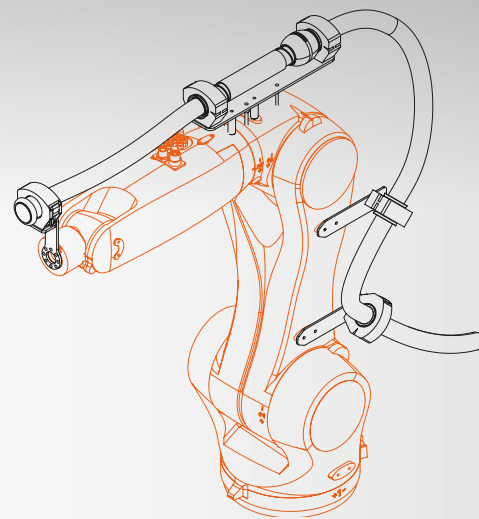

! The light and space-saving recirculation system for small robots such as Fanuc M20iA or Kuka KR6.

OPTIONAL ACCESSORIES

- COLOURED LOCATION MARKERS
- THREAD INSERT SLEEVES
- WEAR RING
- FIXING SET
- SPRING SET
- SLIDER SET

FEATURES

- For hose sizes M25/P21 to 70 Jumbo
- Quick and easy assembly
- Quicker replacement of the hose package or dresspacks without tools
- Especially long service life
- Suitable base plates for each robot type
- System can be built over or stacked

HIGHLY FLEXIBLE CABLE PROTECTION CONDUITS



EWX – HIGHEST CRUSH RESISTANCE IN ITS CLASS

The EWX increased corrugation profile was developed especially for dynamic and heavy stress applications. EWX is known for its high peak pressure resistance and extreme flexibility, which is unparalleled in the industry.

CRUSH RESISTANCE (comparison)

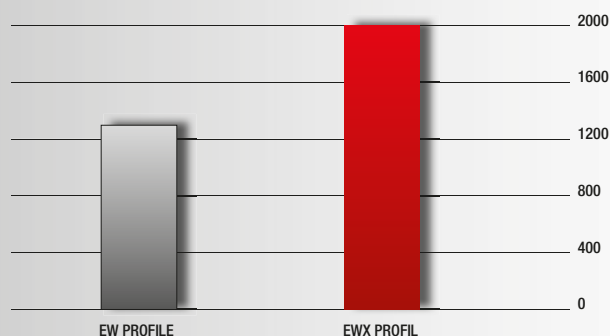

5 MILLION CYCLES – AND NO END

The EW-PAE and EWX-PAE cable protection conduits are made of specially modified Polyamide 12. With its excellent flexural fatigue strength the EWX profile is ideal for robot technology and in handling system areas. This conduit has demonstrated its high resilience, with more than five million cycles in the Murrplastik testing laboratories. It is the first choice for extremely dynamic applications involving medium to high mechanical loads.



MURRPLASTIK Professional tip:

When easy retrofitting is important. Our cable protection conduits are also available in a slotted version.



EWX-PAE

The first choice for dynamic applications. Particularly durable cable protection for industrial robot applications. Outstanding price/performance ratio.

Size	M10/P7 to 95 Jumbo
Colours	Black / grey
Versions	Standard profile (EW) High corrugation profile (EWX) Slotted (LS)
Material	Modif. Polyamide PA 12
Fire classification	HB

EW-PRF

UL-listed. Our export hit for all moving applications, in industry and the skilled crafts sector.
Approved for the US American and Canadian markets.

Size	M10/P7 to 95 Jumbo
Colours	Black / grey
Versions	Standard profile (EW) Narrow corrugation (S)
Material	Modif. Polyamide PA 12
Fire classification	V2 self-extinguishing

EWX-HY

The alternative for low stress applications.
For dynamic handling applications without a recirculation system.

Size	M12/P9 to 95 Jumbo
Colours	Black / grey
Versions	Standard profile (EW) High corrugation profile (EWX) Slotted (LS) Narrow corrugation (S)
Material	Thermoplastic elastomer
Fire classification	HB

INCREASING THE CHAIN SERVICE LIFE WITH SLIDING APPLICATIONS



SLIDING BLOCKS. OUR INNOVATION TO PREVENT WEAR

Murrplastik puts great emphasis on durability, or a long service life, of the energy chains. We not only test the materials continuously, but also search for other innovative solutions. Energy chains that are used in horizontal sliding applications, with travel of longer than three metres, are often subjected to very high mechanical loads.

The consequence is: high wear – they have to be frequently completely replaced. Downtimes increase as a result of repair and/or maintenance periods.

In short: profitability takes a hit. Murrplastik Systemtechnik has developed a simple, ingenious solution to address this problem: the sliding block. The sliding blocks are fitted onto the side links in the energy chain's inside bend without the need for tools of any kind. A screwdriver may be needed merely to disengage a sliding block for removal. Now only

the comparatively inexpensive sliding blocks will need to be replaced when worn, instead of the entire energy chain. Practical tests show that energy chains can gain as much as a fivefold extension to their useful life. As a result, the sliding blocks will pay for themselves after only a short period of use.



WITHOUT SLIDING BLOCK



WITH SLIDING BLOCK



SERVICE LIFE WITH SLIDING BLOCKS

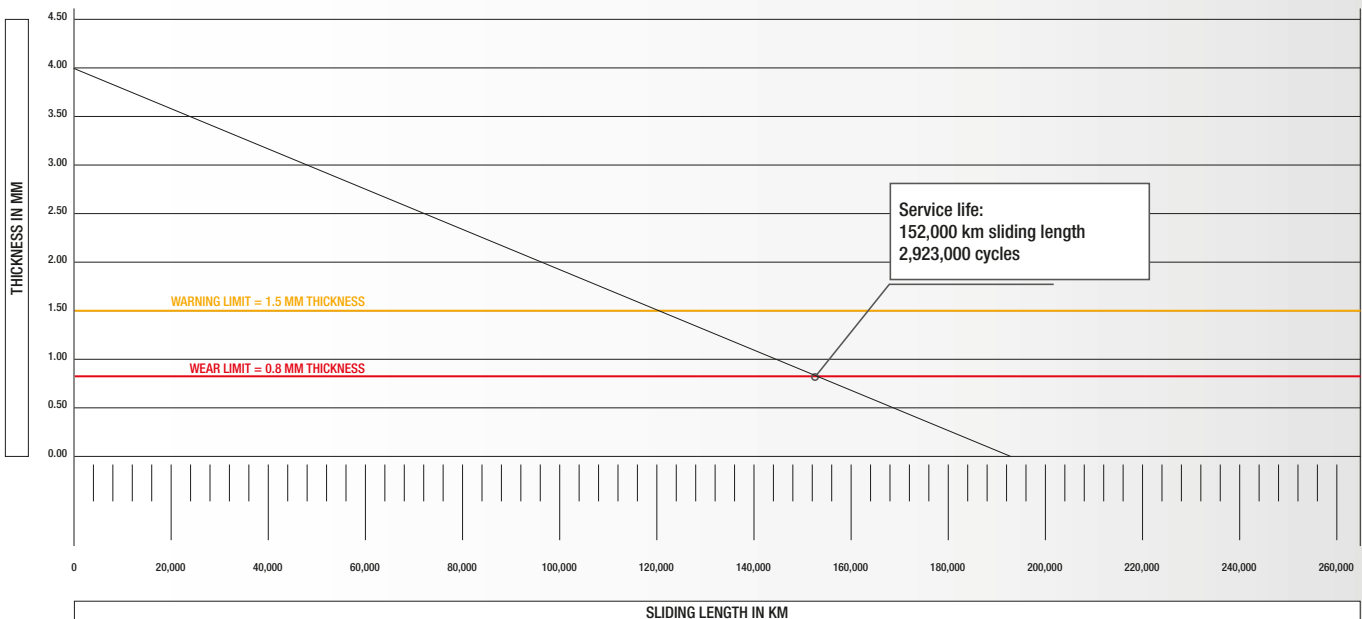

MURRPLASTIK Professional tip:

Based on our test results we recommend replacing the sliding blocks after 152,000 km of moving/sliding use.

NOISE EMISSION WHEN USING AN UNSUPPORTED ARRANGEMENT



noiseLESS. INNOVATIVE MANAGEMENT SYSTEM

Considerable noise emissions are created when using energy chains, especially at high speeds. This is due to the energy chain links not being round and thereby creating noise when rolling off the surface – the so-called polygon effect. By using the specially developed noiseLESS guide channel systems with integrated damping elements, this noise pollution can be reduced by up to 20 dB(A).

LOUDNESS

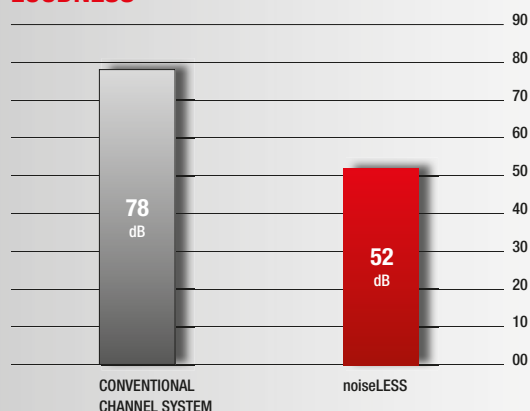

We offer the noiseLESS guide channel system for the following products:

MP 3000, MP 25, MP 30, MP 32.2, MP 41.2 and MP 45.

noiseLESS guide channel systems for other energy chains are available upon request.

noiseLESS FEATURES

- low vibration thanks to solid core design
- variable mounting options
- plastic conduit, available in various colours
- high inherent stability of the aluminium profiles
- anodised surfaces
- plastic end caps with protective function



OUR NOISE ATTENUATING SYSTEM

Thanks to the innovative development of damping elements, we have been successful in reducing noise emissions by up to 10 dB(A) in comparison with conventional energy chains without damping elements. The integrated damping elements function in the inside bend stops and facilitate a significantly quieter unrolling of the chain links.

Since a noise reduction by 10 dB(A) is already perceived as half the noise emission, it is therefore considered a much quieter environment, conducive to concentrated work.

Target applications (please refer to the data sheets of each energy chain model for more specifics):

- Self-supporting applications up to 7 metre travel distance
- Hanging applications up to 50 metre travel distance
- Standing applications up to 4 metre travel distance
- Sliding applications up to 50 metre travel distance

LOUDNESS (effect on stops)

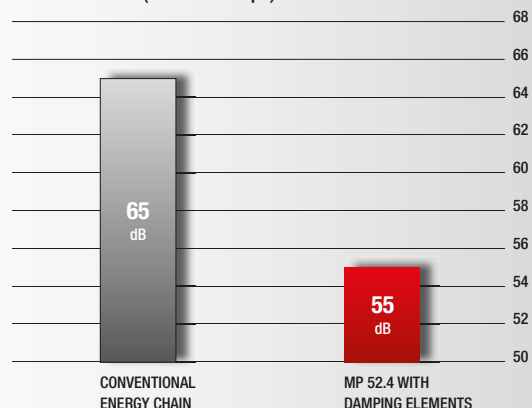

NOISE EMISSION WHEN USING A SLIDING ARRANGEMENT



noiseLESS GUIDE CHANNEL SYSTEM VAW 146

Noise emission is also a big factor when using sliding applications. The solution for this problem is Murrplastik's new noiseLESS VAW 146 guide channel system. We depend on the specially developed guide channel system with integrated damping element for this application as well; noise reduction of up to 10 dB(A) has been recorded (when using the Murrplastik energy chains with damping system, an additional noise

level reduction of up to 10 dB(A) is possible).

The noiseLESS guide channel system VAW 146 is available for the PowerLine chains MP 41.2, MP 52.2, MP 52.4, MP 62.2 and MP 62.4.

noiseLESS guide channel systems for other energy chains upon request.

LOUDNESS MP 52.4

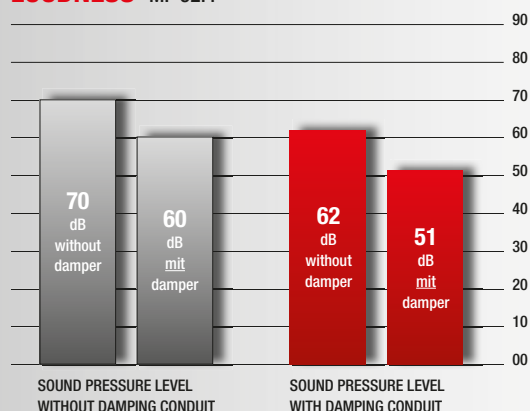

FEATURES

- noise attenuator
- variable mounting options
- Variable chain widths
- Salt-water resistant and corrosion proof



THE LATEST GENERATION ADAPTERS

Energy chains can be securely fixed into guide channels by using the specially developed end brackets adapters. No additional drilled holes required. The new adapters are

available for the ModulLine-, PowerLine and HeavyLine energy chains.



www.mp.de

Germany (Headquarters)

Murrplastik Systemtechnik GmbH
Dieselstraße 10
71570 Oppenweiler
☎ +49 7191 4820
www.murrplastik.de
info@murrplastik.de

America (North/South)

Murrplastik Systems, Inc.
1175 US Highway 50
Milford, OH 45150
☎ +1 513 201 30 69
www.murrplastik.com
cablemgmt@murrplastik.com

China

Murrplastik Asia Co., Ltd.
1802 Rm. No. 218
Hengfeng Rd.
200070 Shanghai
☎ +86 21 512 869 25
www.murrplastik.com.cn
info@murrplastik.com.cn

Denmark

Filial af
Murrplastik Systemtechnik GmbH
Tyskland, Stenager 2
6400 Sønderborg
☎ +45 2347 00 24
www.murrplastik.dk
info@murrplastik.dk

France

Murrplastik S.à.r.l.
Zone industrielle Sud,
6 rue Manurhin B.P. 62
68120 Richwiller
☎ +33 389 570 010
www.murrplastik.fr
info@murrplastik.fr

Italy

Murrplastik Italia S.r.l.
Via Circo, 18
20123 Milano
☎ +39 02 856 805 70
www.murrplastik.it
info@murrplastik.it

Austria

Murrplastik Systemtechnik GmbH
☎ +43 732 660 870
www.murrplastik.at
info@murrplastik.at

Russia

Офис компании
Murrplastik в Москве
Gilyarovskogo 57, building 1
129110 Moscow
☎ +7 495 684 17 37
www.murrplastik.ru
info@murrplastik.ru

Switzerland

Murrplastik AG
Ratihard 40
8253 Willisdorf
☎ +41 52 646 06 46
www.murrplastik.ch
info@murrplastik.ch

Spain

Murrplastik S.L.
Paseo Ubarburu, 76
Pabellón 34, polígono 27
20014 San Sebastián
☎ +34 943 444 837
www.murrplastik.es
info@murrplastik.es

